



KAMUJA

AUTOMATIC CONCRETE FEEDING MIXER FT-4



Output of concrete : 4m³/tank

Hunan Kamuja Machinery & Equipment Co.,Ltd



A Certificated Company of GB/T 19001-2016
ISO 9001:2015

INTRODUCTION

This product can replace generator sets, loaders, mixers and tankers. As well as more than six staff, is a new generation of building industry leading products. The tank can be rotated at 270 degrees with no dead ends on three sides.

FEATURES



① Man-sized radiator

Radiator adopts international advanced panel independent cooling system to ensure this the oil lifter quality and temperature control.



② Duplex gear pump

Duplex gear pump easy maintenance high pressure not easy to wear. It increases the oil inlet and outlet and ensures the required flow rate of the whole machine.



③ Oil-less bushing

The machine uses oil-less bearing wear resistance is 100 times that of a common case because of butter only once a year.



④ Reduction gears of tanker

It uses the BMS large torque motor which is from domestic famous manufacture a reasonable ratio maximizes efficiency.



⑤ Filter(Cleaner)

It adopts self-sealing oil filter with high accuracy and convenient maintenance. Double pump lifter the oil in and out to effectively protect the life of hydraulic parts.

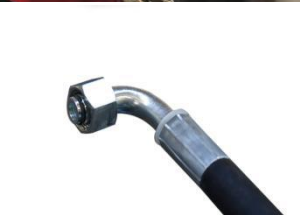

⑥ Tubing

All tubing used international standard joint to make sure there is no oil leak large flow easy to maintenance and universal.

HUNAN KAMUJA MACHINERY & EQUIPMENT CO.,LTD.

Room 818, 4th Floor, Chang Tong Logistic Center, No.18 Qingzhuhu Road, Changsha, Hunan, China



Tel: +86 0731 88677248 alvaro.jin@kamuja.cn www.kamuja.cn

Certificated Company of GB/T 19001-2016/ISO 9001:2015

OVERALL

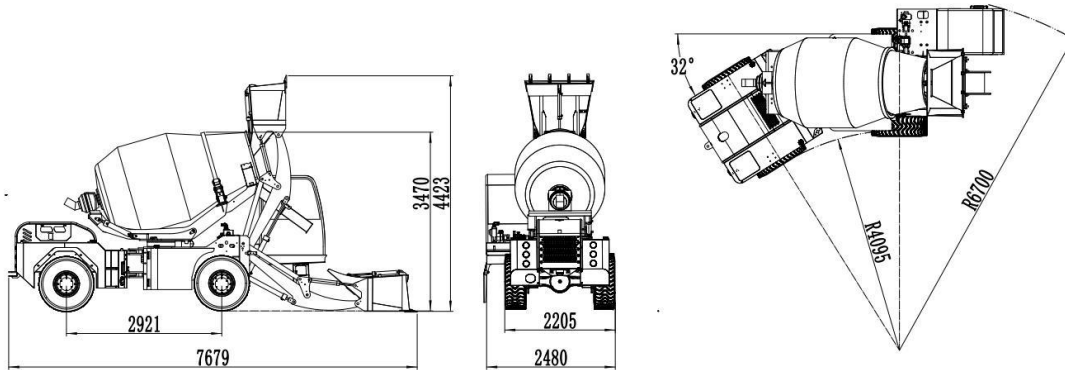

SPECIFICATIONS

Item	Specification	Unit	FT-4
Diesel Engine	Type		YCD4J22T-130
	Total displacement cylinders		4580cc,4-in-line
	Injection		Direct injection and mechanical control
	Cooling system		Water-cooling,dry air filter
	Maximum power	Kw	95
	Maximum torque	N-m/r/min	495/1800
Electric System	Generator		28v-1260W 45A
	Battery		2*12V-60AH(272A)
Speed	The first high speed/second high speed	Km/h	0-17/0-33
	The first low speed/second low speed	Km/h	0-6/0-12
Axle and Tyre	Rear axle oscillating	±	10°
	Tyre		18/70-20
Mixing and Unloading	The geometrical volume of drum	L	5800
	The rotation speed of drum	r/min	25
Equipment Hydraulic System	Maximum flow rate	ml/r	40/80
	Maximum pressure	Map	20
Loading	Capacity	m ³	0.56
	Times		8
Maintenance and Oil filling	Fuel tank	L	158
	Total hydraulic system capacity	L	158
	Engine	L	16
Weight	Operating weight	kg	7760

HUNAN KAMUJA MACHINERY & EQUIPMENT CO.,LTD.

Room 818, 4th Floor, Chang Tong Logistic Center, No.18 Qingzhuhu Road, Changsha, Hunan, China



Tel: +86 0731 88677248 alvaro.jin@kamuja.cn www.kamuja.cn

Certificated Company of GB/T 19001-2016/ISO 9001:2015

	Max Weight	kg	17760
	Load-carrying capacity	kg	10000
Steering	Assisted by double displacement loading sensor power on steering wheel to turn, articulated steering.		
4*4 Four-Wheel Drive	Hydraulic torque converter gearbox, open hydraulic gear oil pump, and reverse gear control to control working speed and travelling speed.		
Brakes	External disc brake and emergency brake acting on four wheels, independent dual circuit brake and hand-control to braking.		
Water system	<p>Hydraulic centrifugal self suction pump injection, the capacity is 14-16m³/h, Inside : it is 150L/min.</p> <p>The total capacity of two connected water tanks positioned opposite is 540L Visual flowmeter, the water intake of the roller by hand-control.</p>		
Cab	Closed cab with heating system,tilting front window, humanized seat flexible suspension and height adjustment are provided.		

※ The technical information may vary by the update policy, the changes will be without prior notice.

HUNAN KAMUJA MACHINERY & EQUIPMENT CO.,LTD.

Room 818, 4th Floor,Chang Tong Logistic Center, No.18 Qingzhuhu Road, Changsha,Hunan, China



Tel: +86 0731 88677248 alvaro.jin@kamuja.cn www.kamuja.cn

|| Certified Company of GB/T 19001-2016/ISO 9001:2015

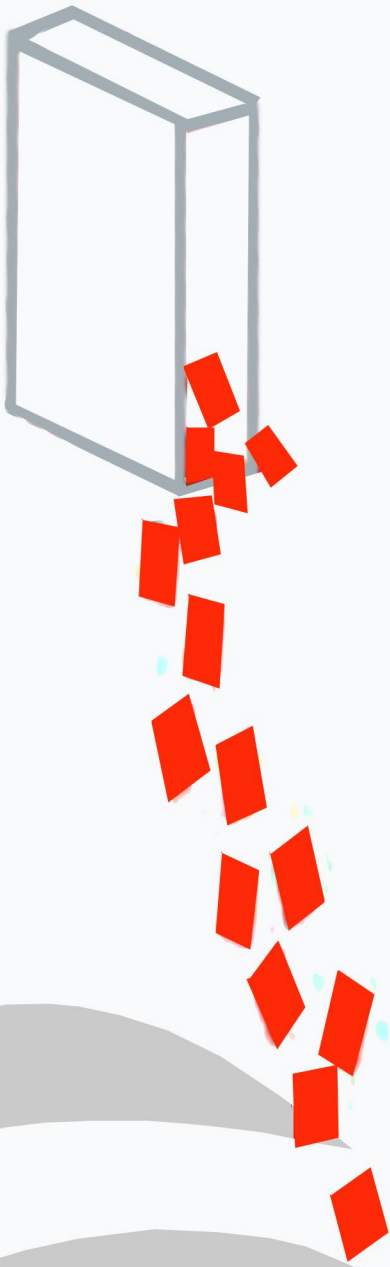

Hunan Kamuja Machinery & Equipment Co.,Ltd

Address: Qingzhu Hu Road N.18, Chang Tong Logistic Center Floor 4 Room 818,
Jinxia Economic Development Zone, Changsha City, Hunan Province, P.R of China.

333 SE 2nd Avenue Suit 2000 Miami FL 33131. USA

Tel: +86 731 8867 7248 e-mail: info@kamuja.cn

Web site: www.kamuja.cn



A Certificated Company of GB/T 19001-2016/
ISO 9001:2015